

# High-Speed Presses— Match Design to Application

Expect certain attributes across all high-speed presses, and look for special features to match your unique requirements.

BY DENNIS BOERGER

Supplying stampings for the electronics, telecommunications, lamination, automotive or computer industries? Then be sure to choose a high-speed press with characteristics designed for the application. It is difficult to apply the one-size-fits-all philosophy to the high-speed-press world because the very nature of the jobs involving these presses demands designs uniquely suited to the individual requirements of each application. Yet a high-speed press should possess certain features regardless of application. Understanding these characteristics helps guide a stamper's choice in equipment.

## High-Speed Needs

A high-speed press should be dynamically balanced with a stiff slide-guiding system. The press also should maintain accuracy under cold, warm, slow, fast and off-center operating conditions. The bed, bolster plate, connecting rods, crankshaft and crown must exhibit greater rigidity than a gen-

*Dennis Boerger is product manager for Aida-America Corp., Dayton, OH. Tel. 937/237-2382, [www.aida-america.com](http://www.aida-america.com).*

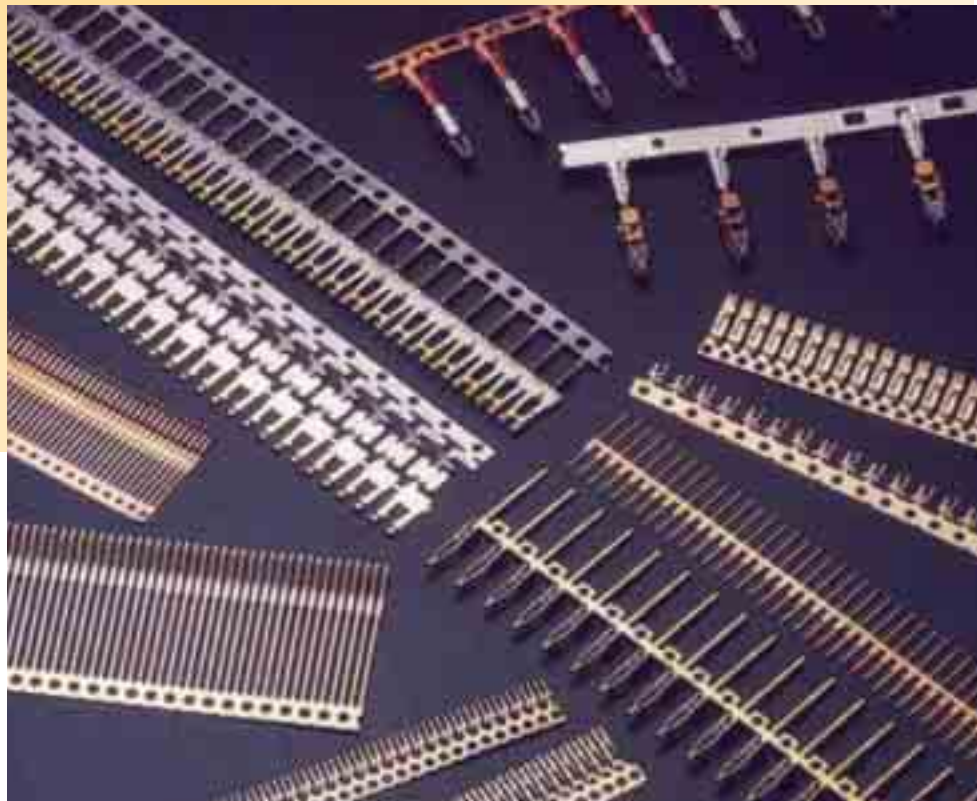

eral-purpose stamping press. Added press stiffness increases the life of the die and improves piece-part accuracy. Greater slide and frame rigidity also minimize deflection caused by off-center loads.

A system combining the advantages of anti-friction and oil-film-type bearings provides good bottom-dead-center (BDC) repeatability at start-up and throughout the speed range. A shut-height adjustment mechanism located off the slide reduces inertia forces and increases the life of the adjustment motor.

A stamper also should seek out a thermally stabilized press. Thermal stabilization can be achieved with a lubrication system that circulates oil to all moving parts and combines with an oil

heater and refrigerant-type cooler. This type of pretimed lubrication system runs heated oil through the press prior to operation to bring the equipment to an ambient operating temperature.

Once the operator starts the press, oil shearing occurs and friction among press components generates heat that can cause significant thermal growth. To counter this effect, oil runs through the chiller to remove heat prior to recirculating back over press components. This cools press components and helps maintain a constant temperature. Such a cooling system provides a stable die space and prevents the shut height from changing as the press warms. Without it, stampers can expect changes in part quality, including inconsistent dimensions.

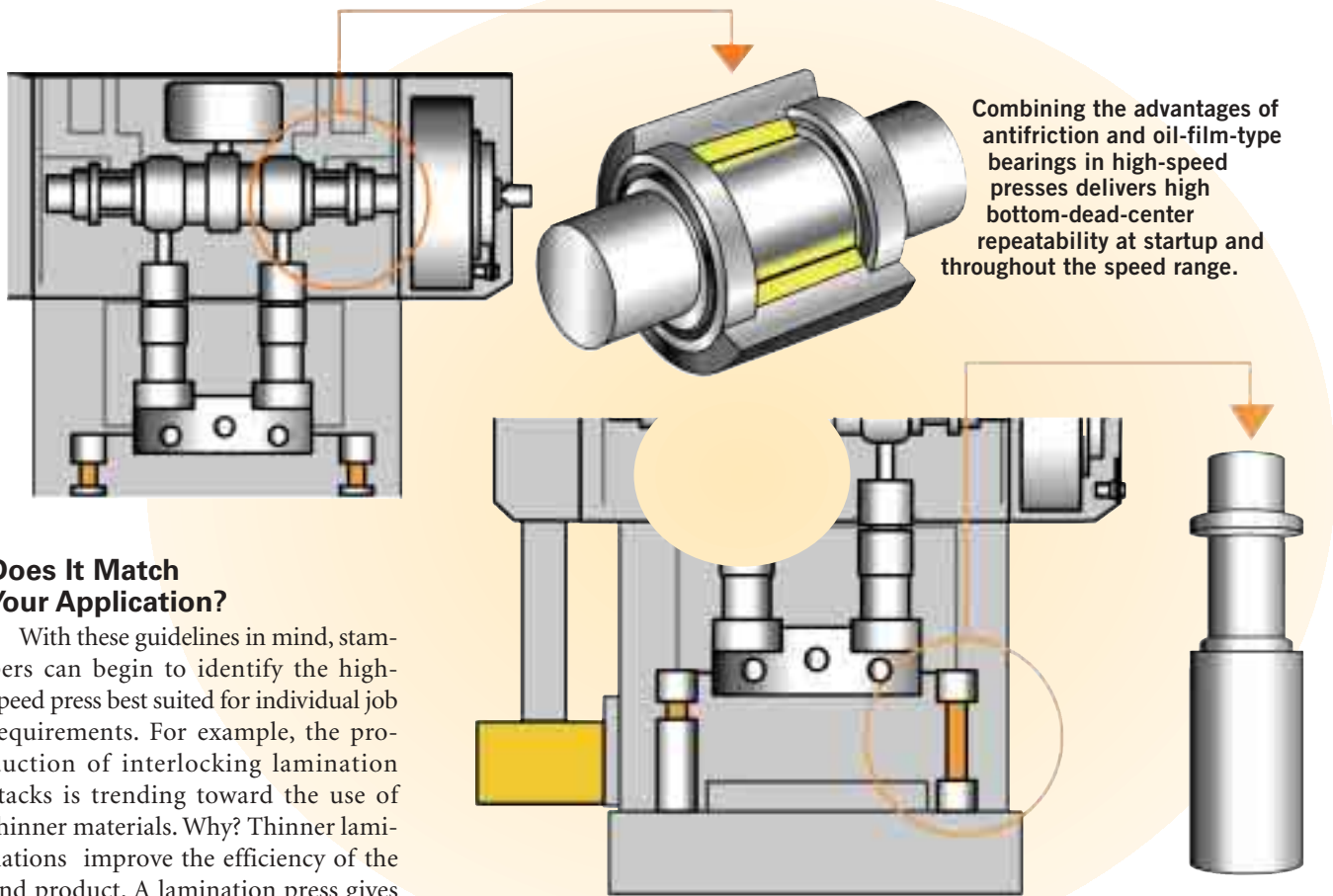

Combining the advantages of antifriction and oil-film-type bearings in high-speed presses delivers high bottom-dead-center repeatability at startup and throughout the speed range.

### Does It Match Your Application?

With these guidelines in mind, stampers can begin to identify the high-speed press best suited for individual job requirements. For example, the production of interlocking lamination stacks is trending toward the use of thinner materials. Why? Thinner laminations improve the efficiency of the end product. A lamination press gives users of high-speed flat-blanking presses the most stable process for production of a variety of laminations, including motor, transformer, E and I, and slinky.

However, for very thin laminations, a conventional high-speed lamination press no longer is appropriate. Consider transitioning to a multiple-suspension high-speed press with the necessary deflection and BDC control capability. This design allows stampers to use extremely thin materials when producing laminations in interlocking stacks.

If applications cover a range of stampings where speed and stroke requirements change, consider a high-speed press that features an adjustable stroke length to accommodate the production tool. The press design must provide the ability to change stroke length to fit the size of the part being run while the die height remains unchanged. For shorter stroke lengths, slide motion should be comparable to crank motion, making it suitable for high-speed operation. For longer stroke lengths, dwell time near BDC is extended, reducing shock and vibration and increasing material flow time. Knuckle

**A stiff, highly engineered slide-guiding system, as shown in this diagram, should be a key component of a high-speed press. Greater slide and frame rigidity minimize deflection caused by off-center loads, and added press stiffness in general increases the life of the die while improving piece-part accuracy.**

motion ensures quality restriking operations at any stroke length.

For dedicated production lines, a high-speed press with a fixed stroke makes a good choice. Whether fixed- or adjustable-stroke models are specified, stampers should consider link motion, which reduces punch contact velocity on the material. The right link-motion design enhances metalforming operations by maintaining the press slide near the bottom of the stroke for an extended period of time. Its ability to reduce punch velocity effectively holds pressure on the workpiece longer, as much as 60 percent longer than with nonlink-motion presses. That additional pressure time improves part dimensional stability and accuracy without lengthening overall cycle time. The modified slide motion from a link drive allows the slide to regain the extra time spent at the bottom of the stroke as it travels over the top.

### Electronics: Mind Speed and Stroke Length

The ideal press design for production of some electronic parts such as connectors features a longer stroke with a high operating speed. Other electronic applications, such as the manufacture of precision miniature electronic parts, may require a press capable of shorter strokes (13 to 20 mm) with operating speeds as high as 2500 strokes/min. Such capabilities in a compact press design save on floor space and reduce initial setup and run costs. Due to the high-speed operation of such a press, the design should feature the combined bearing system described earlier in this article.

Stampers with jobs that don't require speeds to 2500 strokes/min. also might consider a moderately high-speed press (1000 strokes/min. maximum). The lower stroke rate brings a more cost-effective price point. **MF**