

HIGH-TECH PRESSES

Servo technology meets mechanical presses

By Dennis Boerger

Stampers are looking to achieve higher productivity, better component quality, longer die life, and increased flexibility. While these capabilities are essential to maintaining an edge in today's competitive environment, they come at a price. New technology now offers one solution that

can provide these benefits while minimizing the need for large capital equipment investments.

Evolution of Servo Technology

To better understand the impact servo technology will have on mechanical presses, it's important to look at some factors that contributed to its development.

Stampers know the ability to adjust a mechanical press's operating speed, change stroke length, and alter the slide motion can enhance operations, improve part quality, and increase press and tooling productivity. While such adjustments were possible many years ago, press builders found it wasn't cost-

effective because of the rigid design platform upon which the mechanical press drive is based.

However, over the last 20 years, adjustable features for mechanical presses have evolved. Speed adjustment is now standard on most new presses, but modified slide motions and stroke length adjustment are less common on mechanical presses. Although link- and knuckle-drive systems provide modified slide motions, stroke length adjustment is limited primarily to high-speed (200-strokes-per-minute [SPM] and higher) presses.

Early generations of servo technology used high-speed, low-torque servomo-

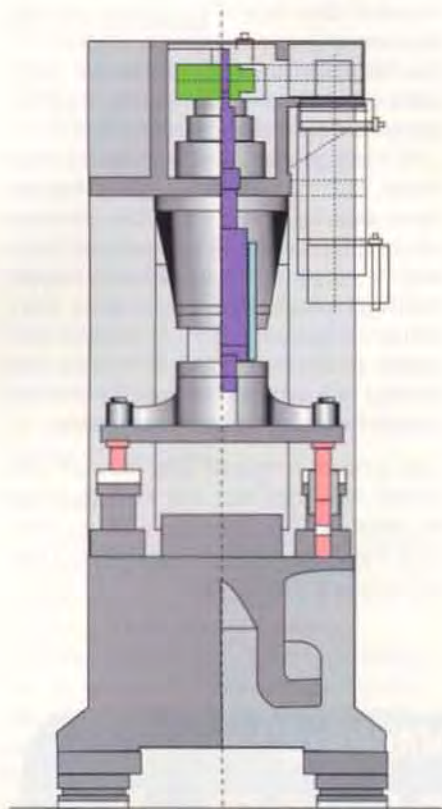

Figure 1
Complex drive system

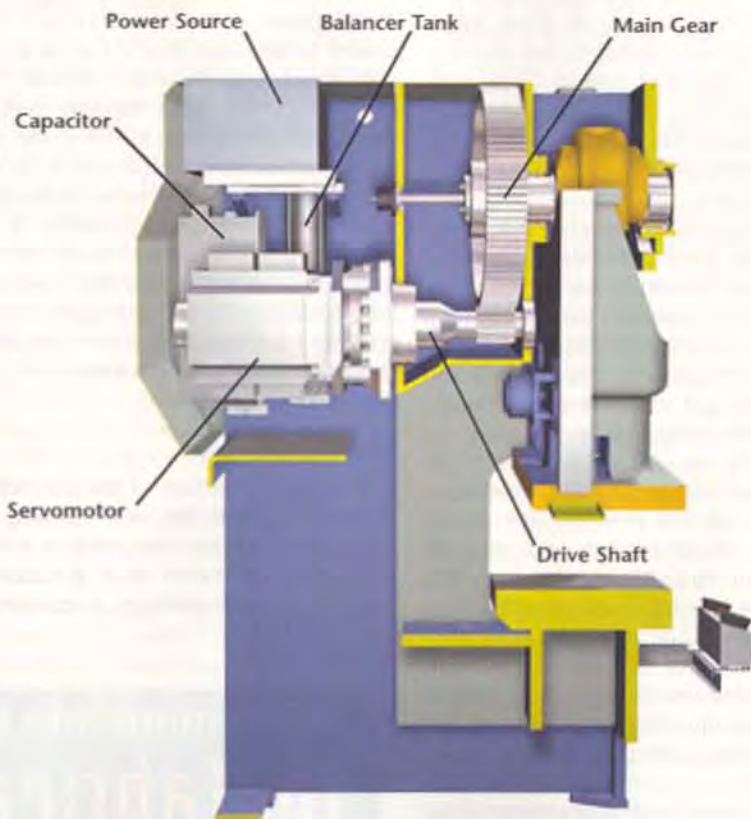

Figure 2

ServoPro™ is mounted directly to the press driveshaft, which eliminates the flywheel, clutch, and drive motor found on standard mechanical presses.

tors initially developed for the plastic injection molding industry. While they were suitable for embossing or blanking, their limited torque and energy capability made them impractical for normal presswork.

High-revolutions-per-minute (RPM), low-torque motors presented a challenge. Difficult to maintain, these complex drive systems added to the cost of the equipment (see **Figure 1**). Operation costs also were high because of the large amount of power these drive systems consumed. The high-RPM drives' limitations and the fragility of their ball screws prompted one press builder to develop a servo-driven Press for general pressworking using low-RPM, high-torque motors.

Benefits of New Servo Technology

AIDA's new servo technology mounts its proprietary servomotors directly to the press driveshaft, eliminating the flywheel, clutch, and drive motor found on standard mechanical presses (see **Figure 2**). This direct drive also removes the need for mechanisms to multiply the torque of a standard servomotor.

In addition, stampers can run a multi-press transfer line in continuous mode instead of in single-stroke mode. In continuous mode, productivity can be increased by as much as 50 percent.

ServoPro™ capacitors store energy in the nonworking portion of the stroke, making power consumption comparable to that of a standard mechanical press.

This technology also gives stampers the flexibility to optimize press operations by providing a fully programmable slide motion and adjustable stroke length with numerous combinations. Possible combinations include crank motion, slowdown at the top of the stroke for automation, intermittent run mode, and continuous run mode. For a blanking operation, stampers can set the minimum stroke length to match the work, allowing a shorter working cycle time as well as a blanking mode that is designed to reduce shock vibrations and noise. Dwell at bottom dead center and knuckle motion also are options.

The technology is also suitable for forming exotic materials such as titanium-magnesium alloys and high-strength steels (see **Figure 3**). A hand-crank option allows stampers to progress through the slide motion manually. This makes it



Figure 3

A bracket formed from high-strength, low-alloy steel with 140 K strength is an example of what can be produced with ServoForming technology.

possible for stampers to actually see what is happening and ensure that die setup and synchronization of ancillary equipment are correct before initiating a production run. This capability helps protect dies and reduces the production of bad parts.

Limitations of Servo Technology

Although ServoForming™ is suitable for most stamping applications, certain job requirements may present limitations. Currently operating speeds peak at 150 SPM or less depending on the stroke length and tonnage capacity. In the production of deep-drawn components, for example, high power consumption is required for a large portion of the stroke, making this type of production process unsuitable for this technology.

Improving part quality, productivity, die life, and the flexibility of manufacturing cells is critical to surviving today's competitive pressures. Servo technology offers stampers a way to achieve these improvements and expand their profit-generating capabilities.

Dennis Boerger is a product manager with AIDA-Dayton Technologies Corp., 7660 Center Point 70 Blvd., Dayton, OH 45424-6380, 937-237-2382, fax 937-237-1995, www.aida-america.com.

Write 4 on reply card